

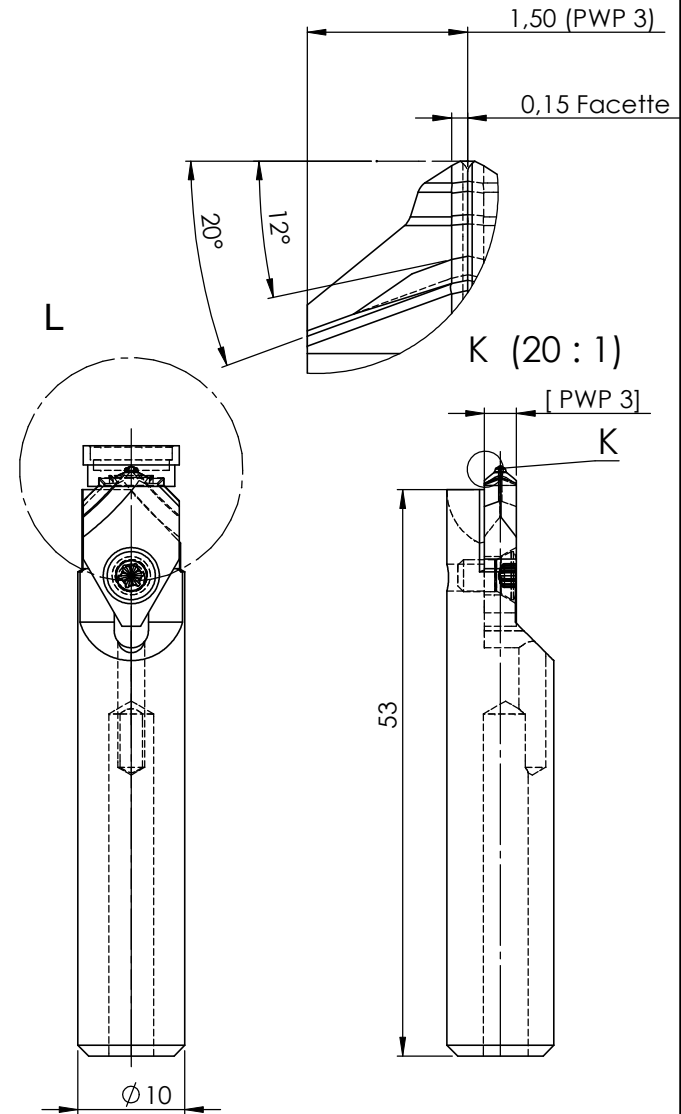

Area X-X = 15°/ 20° Side Clearance  
 Area Y-Y = 15°/ 45° Side Clearance

L 20:1

Customer No.	Article No.

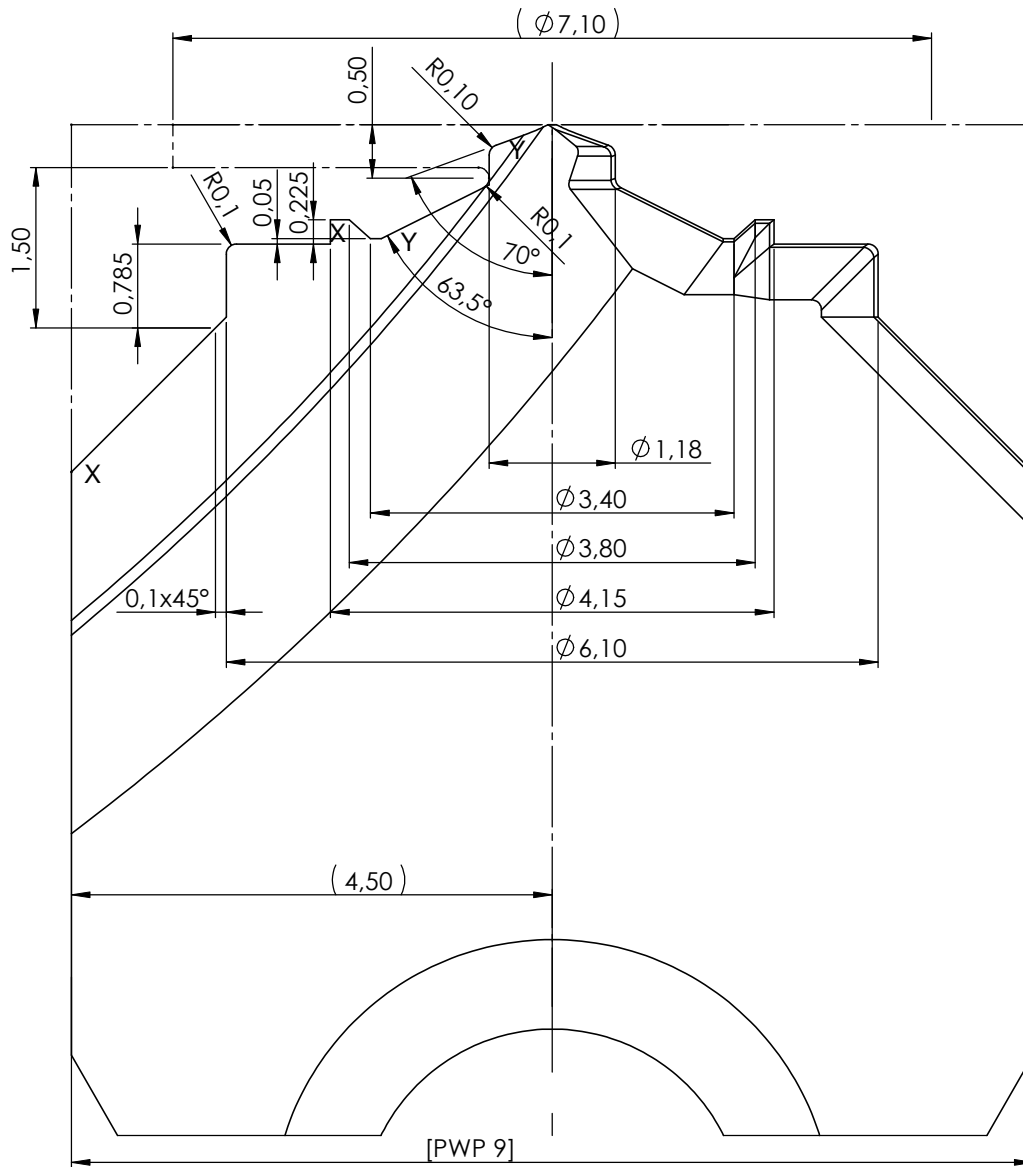

2:1

Front Clearance Angle	12/20°	Angle Insert	0°	1	PWP interchangeable tip with profile	Granit 2000	9x3x16.5	218966
Top Rake Angle	0°	Angle Holder	0°	1	PWP-Tip holder		ø10x53/0°	218966H
Coating	TIN			Pcs.	Description	Material	Raw dimensions	Number
				Drawn by.	Date	Name	Surface-finish DIN ISO 1302	
				Appr. by	20.06.2008	Kieninger	General tolerance DIN 2768 - mK	Profile tolerance: ± 0,02mm
				Norm				
				Scale	Naming: Drill			 Schwanog Siegfried Güntert GmbH Phone: 07727 / 9489-0 Fax: 07727 / 9489-99
				All rights at the company SCHWANOG SIEGFRIED GÜNTERT GmbH, also for the case of legal protection and right registration. Every order of authority, copy and passing on rights by us.				
No.	Revision	Date	Name					Article No.