

X=1 ° SIDE CLEARANCE

Turning Direction (synchronously)  
Helix Angle 13° 8'

Customer No.	Article No.
299149	912455

ALL DIMENSIONS IN INCHES

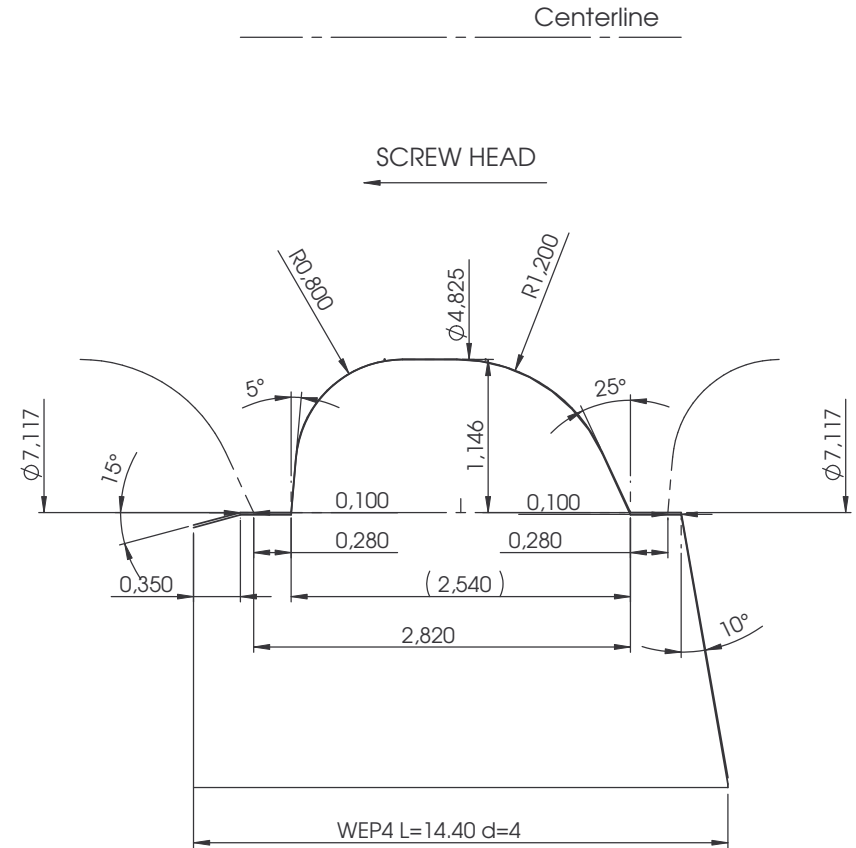
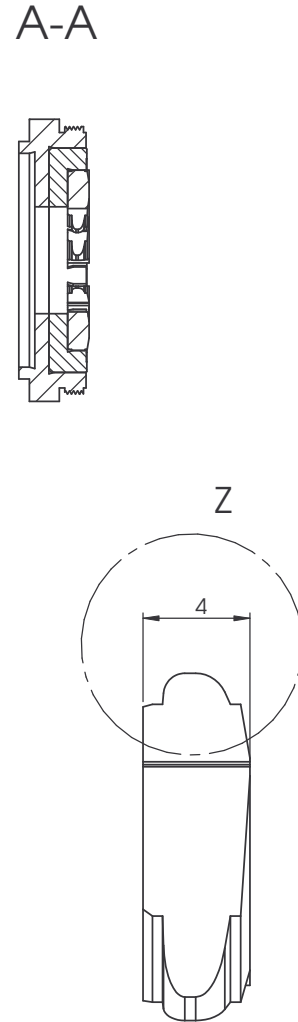
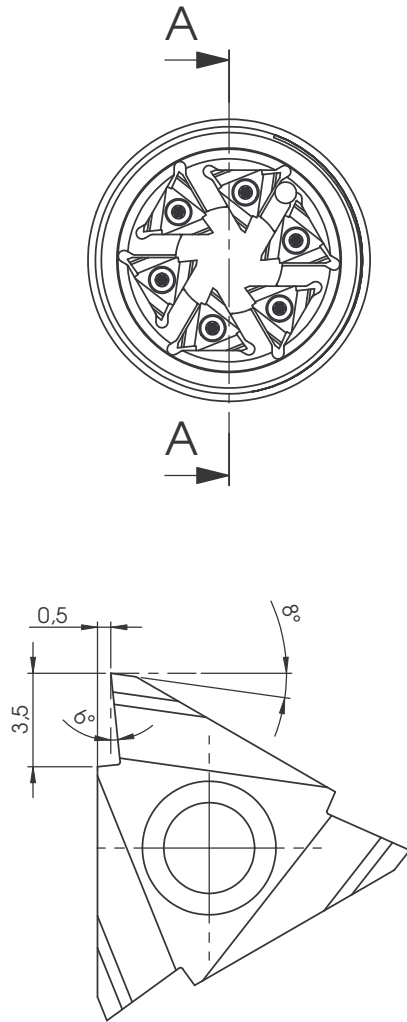

Z (25 : 1)

Front Clearance Angle	8 °	Angle Insert	6 °	6	WEP-Insert	Granit 2000	L=14.40 d=4	
Top Rake Angle	8 °	Angle Holder	0 °	1	WEP-Holder	1.2312		
Coating				Pcs.	Description	Material	Raw dimensions	
					Date	Name	Number	
					13.09.2007	Hauser	Surface-finish DIN ISO 1302	
					Drawn by	Projection	 Schwanog Siegfried Güntert GmbH Phone: 07727 / 9489-0 Fax: 07727 / 9489-99	
					Appr. by	General tolerance DIN 2768 - mK		
					Norm			Profile tolerance: ± 0.02mm
					Scale	Naming:		
					10:1	Ø7,0 Cannulated Ti Bone Screw (Knochenschraube)		
No.	Revision	Date	Name	All rights at the company SCHWANOG-SIEGFRIED GÜNTERT GmbH, also for the case of legal protection and right registration. Every order of authority, copy and passing on rights by us.				Article No. 913455