

OD grooving with Schwanog

ESCOMATIC® SYSTEM

For all machine types



ESCOMATIC® D2 MACHINE



**CONVERTED VENTURA HEAD D2 120 ONTO A
HEXAGONAL SHAFT**



schwanog



The Schwanog ESCOMATIC® System

We offer a high-productive tooling solution for all ESCOMATIC® machines. Besides the insertable form tools, we also offer suitable holders for all types of machines including, cam-type machines D2, D4, D5 and D6 as well as the new D2/D5 CNC and NM Mach machines. The machines in the below-mentioned graphic require the head to be converted to a hexagonal shaft - but this conversion is technically simple and requires only a little effort. The test series have in principle shown that one benefits considerably under all conditions. However, the following applies in particular:

The more difficult the material to be machined, the higher the tool cost savings!

ESCOMATIC® heads



For all other machines the conversion is eliminated. These machines are already equipped with the hexagonal shaft.

The advantages

- Enormous reduction in tool costs
- Due to the highest change accuracy, separate adjustment during tool change is not necessary
- Substantial time savings during tool changeover
- Significantly lower downtime costs due to fewer tool changeovers
- Complete solutions for the entire line of ESCO machines



Machine types

D2/D4/D5, D2 FLEXSPEED, D2 CNC UP

Ø 120 mm

Head must be converted onto a hexagonal shaft.



D6

Ø 126 mm



D2/D5 CNC, D5 CNC ULTRA, D5 TWIN

Ø 90 mm

Head must be converted onto a hexagonal shaft.



NM6 FLEXI, NM6 TWIN

Ø 96 mm

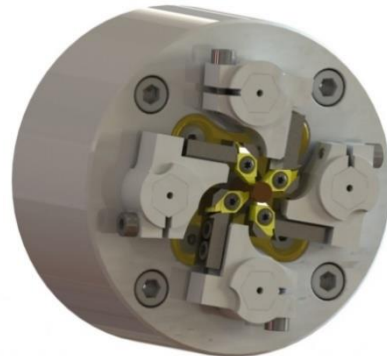

NM8 FLEXI, EC08

Ø 140 mm

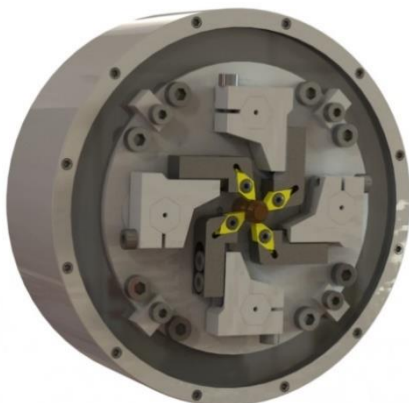

EC12

Ø 150 mm

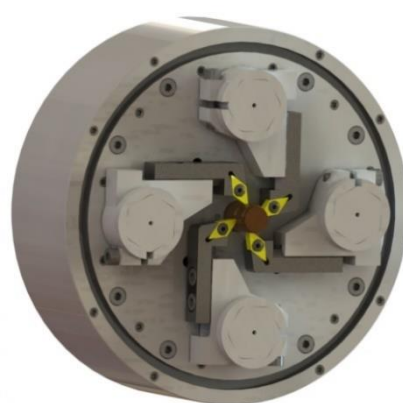



ESCOMATIC® holders

D2/D4/D5, D2 FLEXSPEED, D2 CNC UP

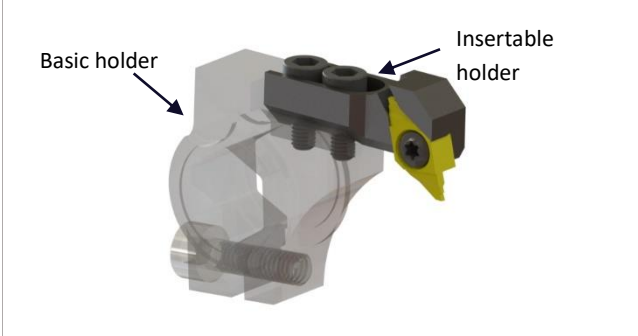

D6

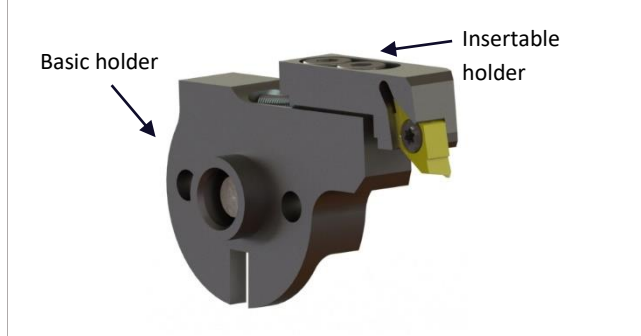

D2/D5 CNC, D5 CNC ULTRA, D5 TWIN

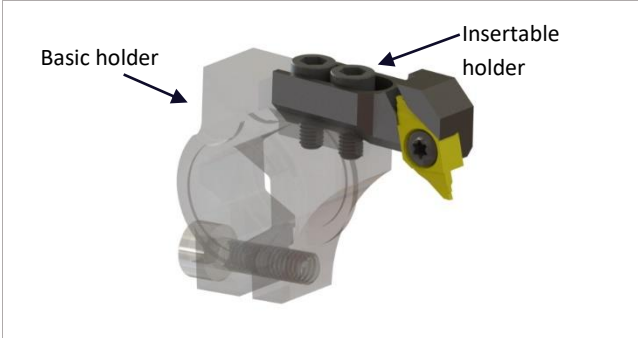

NM6 FLEXI, NM6 TWIN

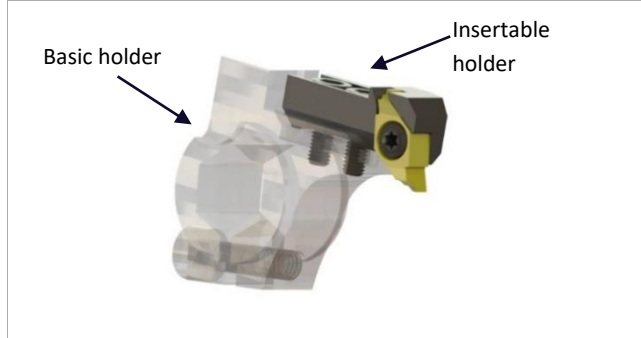

NM8 FLEXI

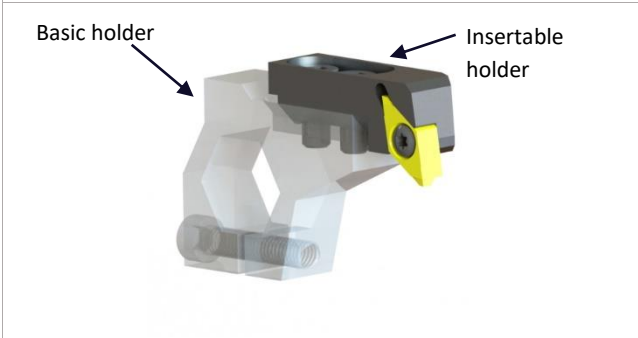

EC08

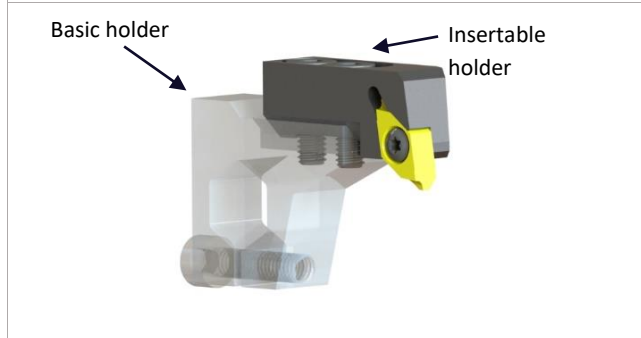

EC12

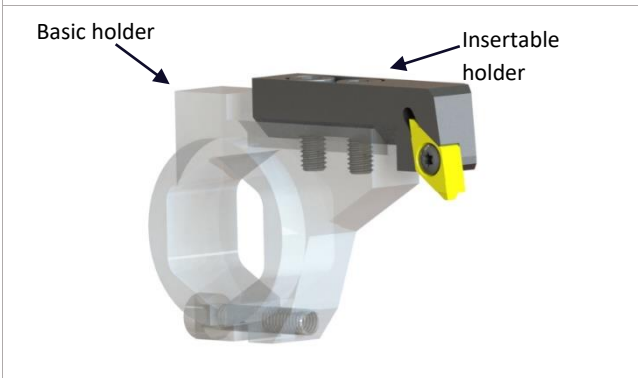



Schwanog tools for ESCOMATIC® machines

Machine	Head diameter	Basic holder	Insertable holder	Left/right	System
D2 D4 D5 Curve D2 CNC UP D2 FLEXSPEED	∅ 120 mm	Conversion is required. Basic holder existing by conversion	288503	Left	DCI 15,70 2 edges
			288501	Right	DCI 15,70 2 edges
			323880	Left	DCI 19,01 2 edges
			327124	Right	DCI 19,01 2 edges
D6 Curve	∅ 126 mm	279344	274484	Left	DCI 15,70 2 edges
			284498	Right	DCI 15,70 2 edges
			334989	Left	DCI 19,01 2 edges
			338227	Right	DCI 19,01 2 edges
		298516	Left	WEP 3 edges	
		298427	Right	WEP 3 edges	
D2 / D5 CNC D5 CNC ULTRA D5 TWIN	∅ 90 mm	Conversion is maybe required. Basic holder existing by conversion	288503	Left	DCI 15,70 2 edges
			288501	Right	DCI 15,70 2 edges
NM6 FLEXI NM6 TWIN	∅ 96 mm	Basic holder comes with the machine	288505	Left	DCI 15,70 2 edges
			288504	Right	DCI 15,70 2 edges
			337139	Left	DCI 19,01 2 edges
			337137	Right	DCI 19,01 2 edges
NM8 FLEXI	∅ 140 mm	Basic holder comes with the machine	316244	Left	DCI 15,70 2 edges
			316245	Right	DCI 15,70 2 edges
EC 08	∅ 140 mm	Basic holder comes with the machine	316243	Left	DCI 15,70 2 edges
			316242	Right	DCI 15,70, 2 edges
EC12	∅ 150 mm	Basic holder comes with the machine	316247	Left	DCI 15,70 2 edges
			316246	Right	DCI 15,70 2 edges



SCHWANOG – Reducing cost is our job!

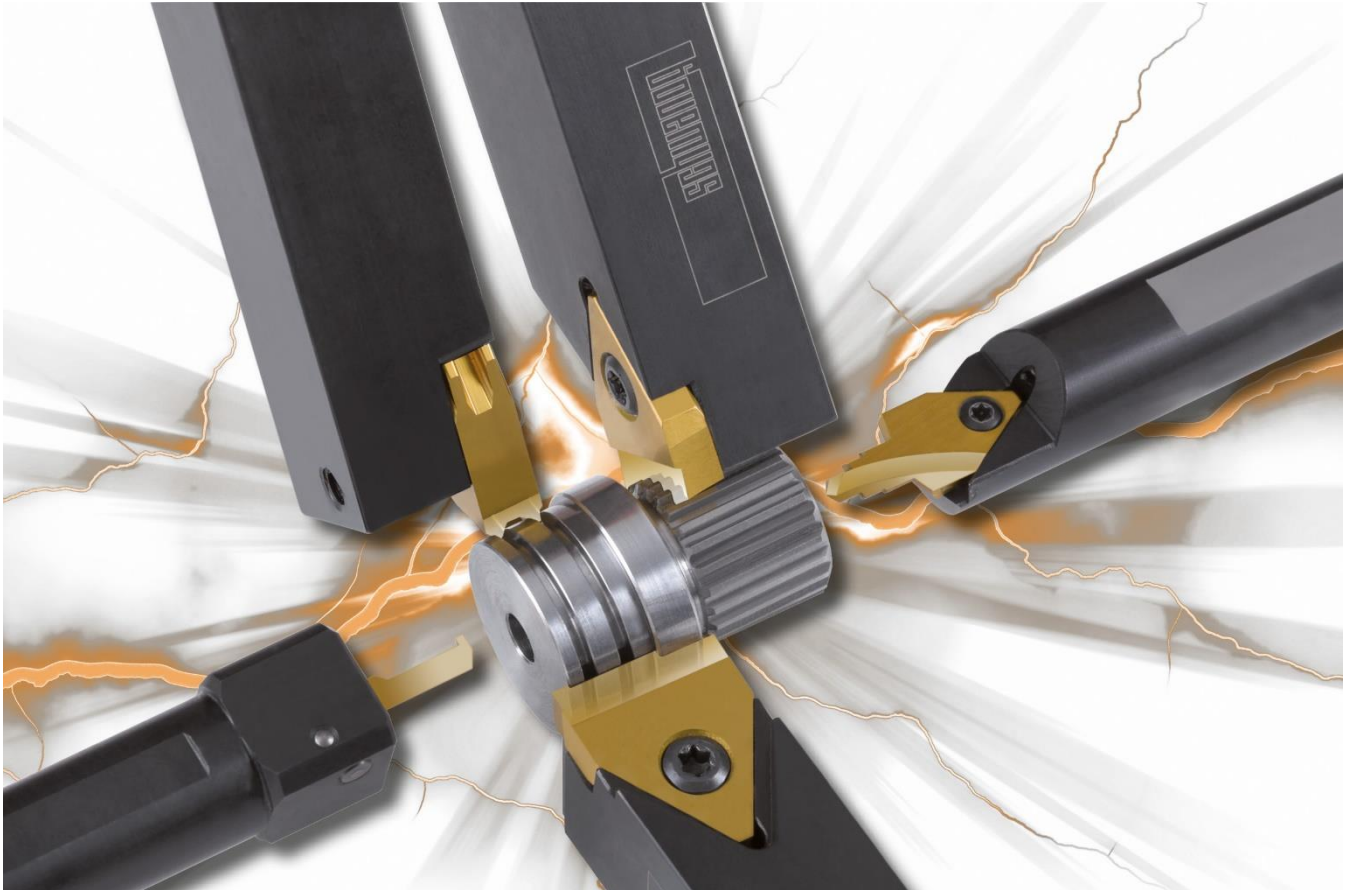

Simply call us or send us your part drawing!

Schwanog Siegfried Güntert GmbH
Niedereschacher Str. 36
78052 Villingen-Schwenningen
Tel. +49 (0) 77 21 / 94 89-0
Email: info@schwanog.com
www.schwanog.com

