

# NEWS.

THE SCHWANOG NEWS FOR CUSTOMERS,  
EMPLOYEES, AND FRIENDS OF THE COMPANY.

**PAGE**  
**03** 6. Schwanog Technology Days 2022:  
We cordially invite you to a dialogue, together with our  
technology partners in Villingen-Schwenningen ...



**PAGE**  
**04** Coolant exactly where it is needed!  
Schwanog insert holders, for whirling heads with  
internal coolant through, are providing coolant right  
at the cutting edge....



KHK Group relies on Schwanog form drills:

**PRODUCTION TIME  
REDUCED BY 39%!**

**PAGE**  
**02**



## EDITORIAL:

**Dear business partner,**

Today we present you the fourth edition of Schwanog News with exciting reports and stories from the world of Schwanog.

With great pleasure, we invite you personally to the Schwanog Technology Days in June of next year, where we can finally give you a warm welcome. Our event team is committed to work diligently on the concept and content and we are convinced that we can offer you an attractive program once again.

Our mission is to generate adequate solutions and productivity advantages for you - our customers. The reports in this edition are complementing this very well, for example, the cover story with the KHK Group, where we were able to reduce the production time by 39% using Schwanog form drills. Please read more on page 2.

You can find another exciting product report on page 3. With our WEP system, grooves can be milled particularly efficiently instead of using conventional carbide milling cutters, and the part costs can be reduced significantly. On page 4 we keep a cool head by providing significantly longer tool life and perfect chip removal with our insert holders for whirling heads with internal coolant through, supplying coolant directly onto the cutting edge.

We would like to direct your interest to the trade show calendar 2022, which is packed with interesting trade shows around the world. It would be a great pleasure to meet you there again in person.

Finally, on behalf of all our employees, I wish you a Merry Christmas and a successful 2022!

Clemens Güntert  
Managing director

**SCHWANOG**

KHK Group uses Schwanog insertable form drills:

## REDUCTION OF PRODUCTION TIME BY 39%!

The KHK Group, consisting of Gerd Krüger Maschinenbau GmbH, Industribedarf Krüger GmbH, and Czetec spol sro has positioned itself, since the company was founded in 1961, as a proven specialist in rotary and swivel screw connections as well as in the manufacture of hydraulic valve blocks for high-quality precision parts.

At the company headquarters in Brockel, Lower Saxony, and the production site of Czetec spol. sro in the Czech Republic, about 50 employees produce high-quality parts for the hydraulic industry. Materials such as aluminum, steel, and stainless steel are mainly used

**Rotary and swivel screw connections are core competence.**

The core competence of the KHK Group are rotary and swivel screw connections for almost every medium, every connection, and every size. The medium-sized company structure offers the asset of high flexibility in manufacturing individually dimensioned rotary and swivel screw connections which can also be adapted to the respective customer specifications.

Another success factor for owner and managing director Karlheinz Krüger is the consistent focus on 100% quality made in Europe, paired with decades of experience and highly qualified employees. The necessary purchased vendor parts are obtained exclusively from leading brand manufacturers with the same quality philosophy. Before delivery, every rotary and swivel screw connection are consistently tested for 100% leakage.

### Cooperation with Schwanog since 2019.

The cooperation with Schwanog started around two years ago and has been highly worthwhile thanks to the enormous increases in productivity. Due to the know-how and advice from Schwanog's technical sales representative, Klaus Rosenfeld, KHK Group has been convinced to use Schwanog insertable form drills.

Schwanog PWP insertable form drills are used for the complete machining of valve blocks. The result not only impressed the whole team of managing director and project manager Karlheinz Krüger, but also met the previously projected savings potential.



### Managing director Karlheinz Krüger is enthusiastic:

*"By using Schwanog insertable form drills, we were able to reduce the production time for the entire valve block by 39%. Also, we are impressed by the enormous process reliability with constant compliance of the manufacturing tolerances as well as the first-class, lasting surface finish quality in the sealing area of the bore."*

According to Karlheinz Krüger, the production time required for machining, prior to converting to Schwanog form drills, was 14 minutes for a complete component. With the Schwanog PWP insertable form drills, the machining time could be reduced to 8.5 minutes while maintaining highest process reliability at the finishing process of the part, without the need of a post process.

Another benefit is the long tool life of the PWP insertable tools of 800 drill holes, which is significant for the economic series production of the KHK Group.

Regarding these first-class results, fast response time, and on-site service, we will always consult Schwanog in future projects, according to Karlheinz Krüger.



Drilling of valve block using 2 Schwanog PWP insertable form drills



From left to right: Production manager Timm Dyck and managing director Karlheinz Krüger

Loyalty and reliability lasting over two decades:

## JÜRGEN JAUCH CELEBRATES 25TH ANNIVERSARY!

As a company, we are particularly proud to have so many long-term employees on our team who are such an important success factor, with their experience, loyalty, and reliability. Best example is Jürgen Jauch, whom we congratulated recently on his 25th anniversary.

His career at Schwanog dates to 1996, when he joined us after completing his apprenticeship as a toolmaker. After joining Schwanog, Mr. Jauch was entrusted with the production of the Schwanog tool holders. From the very start until today, he has been a pioneer in this area and has accompanied the entire technological development of production on the STAMA milling centers.

Jürgen Jauch is 51 years old and married. His favorite hobby is music, which he enjoys as an active member in the local music club. He plays two demanding instruments, the flugelhorn, and the trumpet.



From left to right: Production manager Franz Hummel, Jürgen Jauch, and managing director, Clemens Güntert

Welcome to the Dialogue of Specialists:

## INVITATION TO THE 6TH SCHWANOG TECHNOLOGY DAYS 2022!

After having to cancel in 2020, due to pandemic, we are even more pleased today to welcome you to the 6th Schwanog Technology Days from June 22<sup>nd</sup> to June 23<sup>rd</sup>, 2022. This began in 2010 as an informal meeting with some customers and partners and is now the most important event for our company. In these meetings we generate new impulses for the future through personal exchange and inspiration.

Our aim together with our technology partners has always been to offer you, our customers, specific solutions to reduce costs and increase competitiveness, now as then.

The last two years have clearly shown the impact of reliable partnerships, especially for medium-sized companies like ours. Another beneficial perspective of the sixth Schwanog Technology Days taking place at the exact right date is because we are also happy to celebrate our 75th anniversary together with you at this event.



75 years of Schwanog – an exciting company history. One of the important milestones has been the strategic decision in 1997 to focus on the development and manufacture of insertable form tool systems. Today we are one of the world's leading companies in this market segment, with production sites in Germany, France, the USA, and China. We will continue to expand in the

future, supported by our passion for innovative solutions and the entrepreneurial courage to keep breaking new grounds.

The event concept of the sixth Schwanog Technology Days also includes a journey into the history of 75 years of Schwanog. Our technology partners will be holding exciting specialist lectures and, in addition to workshops and company tours, there will be enough time for informal exchange.

We will inform you in time about all event details in the next issue of our Schwanog News in February 2022.

Please add the date to your calendar today – thank you very much!



Schwanog WEP system with 8, 3-sided indexable cutters:

## MILLING GROOVES, THE MOST PRODUCTIVE WAY!

Slot milling is one of the typical machining processes in the manufacture of precision parts. For this purpose, solid carbide milling cutters are still being used in general, although the Schwanog insertable tooling system has long been an alternative that can significantly reduce both set-up times and part costs.

You can now use the highly productive and versatile Schwanog WEP system for your slot milling applications.

Our technical sales team will be happy to advise you!

### Advantages:

- **No regrinding**  
The time-consuming regrinding of solid carbide milling cutters is eliminated
- **Lower coating costs**  
Coating costs are significantly lower as only the insertable tools are coated and not the entire tool
- **Lower setup costs**  
Once worn, the 3-sided tool is indexed or exchanged - the cutter body remains in calibrated position
- **Maximum flexibility**  
The cutter body is universal, i.e., with new geometries, only the insertable tools are changed
- **Significant cost reduction for family of parts**  
When manufacturing family of parts, setup times can be significantly reduced due to the universal cutter body
- **Reduction of tool balancing times**  
Tool balancing already takes place directly in the 3D design phase and thus lowers the setup costs on the machine
- **We can do it all**  
Generally, we are able to manufacture standard as well as special milling cutter bodies

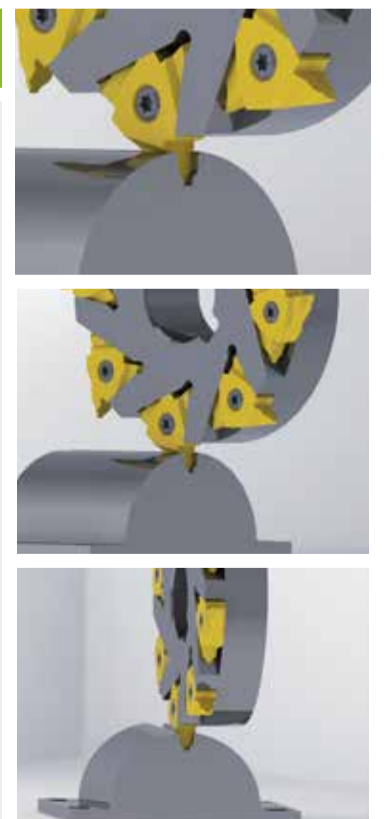

Schwanog insert holders with coolant through:

## COOLANT EXACTLY WHERE IT IS NEEDED!

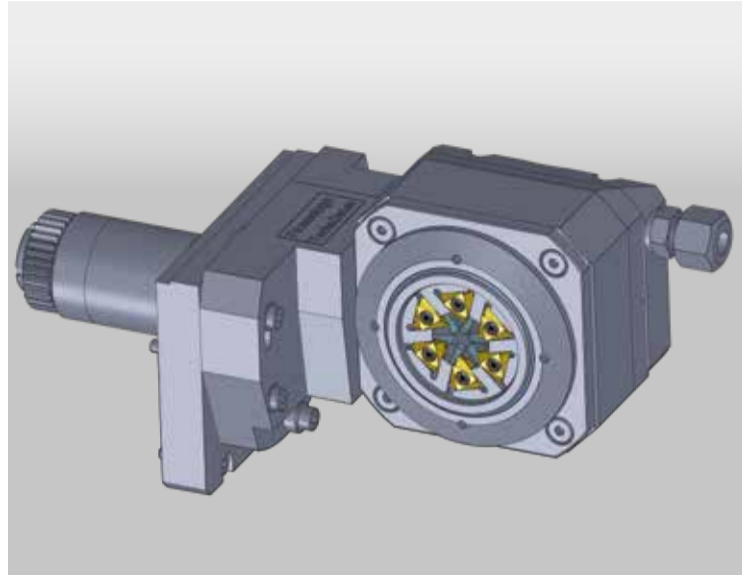

Thread whirling is one of the absolute success stories of the Schwanog system, and for us it is a confirmation and challenge at the same time to keep getting better. Insert holders with coolant through are an enormous achievement, shown here in the example, with a special customized solution with a Schwanog insert holder suitable for a STAR whirling head.

Production processes can be noticeably optimized without chip congestion, with longer tool life, and additionally improved surface quality.

In general, almost all machine manufacturers, and manufacturers of driven tools, offer whirling heads that are suitable for Schwanog whirling tools. But of course, Schwanog has also developed the right insert holder for the various machine types for thread whirling on post-processing machines.

### Advantages:

- No more chip congestion
- Longer tool life of the insertable tool
- Significant increase in productivity by up to 40%
- Improved surface quality
- User-friendly interface

With full steam into a dynamic trade show year:

## SCHWANOG 2022 TRADE SHOW PREVIEW!

2022 will again be a real trade show year with numerous excellent trade shows in all parts of the world. Below you will find an overview of trade shows in which Schwanog will participate. You will receive details about the trade shows in time via newsletter, Schwanog News, social media channels, and our website.

### ITALY



February 18 to 19, 2022 Erba (CO), Lake Como, Italy, Hall A, Stand 78

### AUSTRIA



May 10 to 13, 2022 in Wels, Austria Hall 20, Stand 0833

### GERMANY



September 13 to 17, 2022 in Stuttgart, Germany, Hall 1, Stand 1B80

### MEXICO



January 18 to 20, 2022 in Mexico City, Mexico, Stand 1335

### FRANCE



March 08 to 11, 2022 in La Roche sur Foron, France, Stand D17

### USA



September 12 to 17, 2022 in Chicago, USA Stand 432061

Relax and enjoy with family and friends:

## MERRY CHRISTMAS AND A HAPPY, HEALTHY NEW YEAR!

After a year that has once again challenged us all in every respect, we wish you and your family a Merry Christmas, the best of health, and lots of success for 2022.

Together with our strong team of all employees: we are proud and grateful at the same time for the partnership with you. Let's make the year 2022 a success together.

We are by your side!

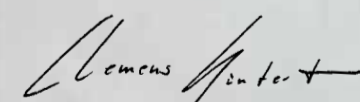
  
Clemens Güntert  
Managing Director



Schwanog · Siegfried Güntert GmbH  
Niedereschacher Str. 36 · D-78052 Villingen-Schwenningen  
Tel. +49 (0) 77 21 / 94 89-0 · Fax +49 (0) 77 21 / 94 89-99  
info@schwanog.com · www.schwanog.com