

NEWS.

THE SCHWANOG NEWS FOR CUSTOMERS,
EMPLOYEES, AND FRIENDS OF THE COMPANY.

PAGE
03 We would like to congratulate our long-standing employees!
During a small ceremony, Managing Director Clemens Güntert took the opportunity...



PAGE
03 Roughing with Schwanog now in 4 widths!
Roughing with interchangeable inserts and sintered chip breaker are more and more in demand...

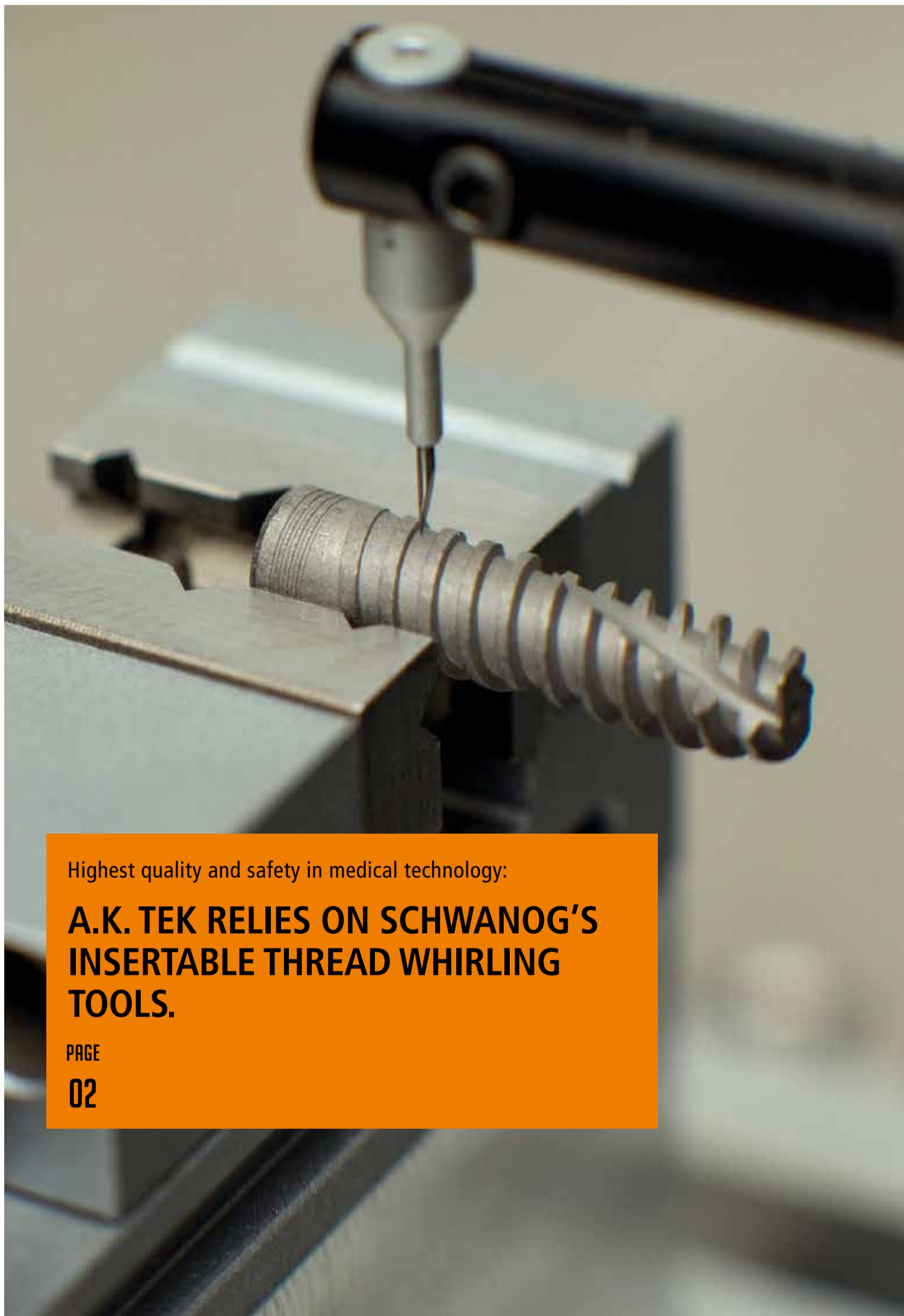
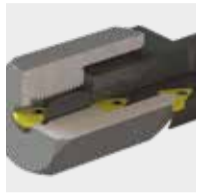

Highest quality and safety in medical technology:

A.K. TEK RELIES ON SCHWANOG'S INSERTABLE THREAD WHIRLING TOOLS.

PAGE
02



EDITORIAL:

Dear business partner,

Under changed global conditions, we started the new decade with courage and great motivation. But the massive spread of the coronavirus suddenly presents us with completely new challenges and unfortunately, we do not have any experience to guide us.

With a heavy heart and in view of current developments, we have decided to postpone our 6th Schwanog Technology Days until next year. We are sure that we have made the right decision in your interest. Further information on this topic can be found on page 3 of this news.

The challenge now is to master this situation successfully together. More than ever, it is a matter of exploiting all the productivity potential that is available to our customers. We know from our daily work that there are still great opportunities in all areas of precision parts manufacturing. The best example for this is our customer A.K. TEK in Hagen which we are introducing on page 2.

Another example is the Schwanog step drill with insertable tools presented on page 3. Here we talk about the immense advantages of a quick tool changeover with Schwanog - without the need to adjust the tool, which would otherwise be the case with solid carbide drills.

You can also read about all the other interesting topics from the world of Schwanog in this new issue.

Let us together meet the challenges and mastering the future - our team is looking forward to your projects!

Clemens Güntert
Managing director

SCHWANOG

Highest quality and highest safety in medical technology:

A.K.TEK IN HAGEN RELIES ON SCHWANOG'S EXPERTISE WITH INSERTABLE THREAD WHIRLING TOOLS.



A.K. TEK managing director Michael Arndt describes the philosophy as follows:

"Every day is learning for us. We analyze natural forces, such as those that make the jaw effective for chewing. We transfer these into technology and in this way create technological high-precision products. These are miniature products that serve as substitutes for something that has been lost in a human body.

The company offers development competence combined with high-end production technology, intelligent surface technology and continuous quality assurance - from single-item to batch production. Manufacturing processes include turning and milling, wire-cutting, plastic injection molding, laser welding and laser marking, and labeling.

In its production facility, A.K. TEK has been relying on the cooperation with Schwanog for over 13 years. The company makes use of Schwanog's expertise with insertable whirling tools in various designs. Before the partnership with Schwanog, whirling systems from other manufacturers were used. The switch to Schwanog was initially made with the intention of lowering unit costs and reducing set-up and ancillary costs.

For Schwanog, the longstanding cooperation with A.K. TEK is the best example of how close technology partnerships and an open approach to challenges can achieve the maximum benefit for both parties.

The company A.K. TEK is a competent development and manufacturing partner in the medical sector, particularly for the dental implantology as well as for endoscopic and spine surgery. With a pioneering spirit and curiosity, the company closely cooperates with surgeons, clinics, and institutes.

The team from A.K. TEK is mainly composed of professionals with multiple qualifications. In addition to basic metalworking expertise, they have undergone additional training or studies. They are highly qualified technicians in the manufacture of medical products with many years of experience.

A.K. TEK designs the manufacturing process in its entirety, from blueprint to finished product. The team is trained in terms of products and processes, and takes an integrated-process approach to machining, materials, applications and technologies.

„The decision to switch to Schwanog tooling systems was primarily taken for reasons of cost optimization. And the result convinced us from day one, so now only Schwanog is now used for whirling applications.

We are also impressed by the ease of use of Schwanog's insertable tooling system. A constant high quality with repeat orders is extremely important to us, as well as short turnaround times and the competent support of Jörg Hönle and the Schwanog Team in VS-Obereschach.

Mr. Böse, head of production at A.K. TEK

A.K. TEK is active in three business segments:

- **Dental Implantology**
with dental regulating components, implant systems and retaining elements
- **Spine Surgery**
with artificial intervertebral disc housings, bone screws, and surgical individual solutions
- **Endoscopic Surgery**
Components for endoscopic surgery



Schwanog solutions for Escomatic machines:

A HEAD CONVERSION FOR D2 AND D4 MACHINES IS ALWAYS WORTHWHILE!

Our tool program for Escomatic machines has become well-accepted since the successful market launch. At the suggestion of numerous customers, we have selectively expanded our product range and offer a high-productive tooling solution for all Escomatic machines.

Besides the insertable form tools, we also offer suitable holders for virtually all types of machines including, New Mach, EC08 or EC12.

Exception are the D2 and D4 Escomatic machines here the head must be converted onto a hexagonal shaft. Although this is associated with a small expenditure, the productivity leap in the subsequent application of our tools makes this quickly forgotten. Numerous customers who use D2 and D4 machines have already adapted the heads to our system and are absolutely delighted with the resulting precision and productivity.

In short: the head conversion is always worthwhile!



Converted D2 120 head onto hexagonal shaft

Current status regarding the development of the coronavirus:

POSTPONEMENT OF THE 6TH SCHWANOG TECHNOLOGY DAYS!

6. SCHWANOG TECHNOLOGIETAGE

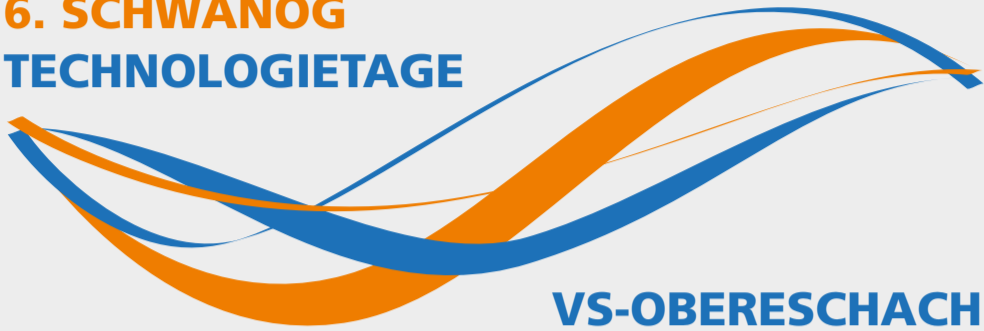

With a heavy heart we have decided to postpone our 6th Schwanog Technology Days until next year, in view of the current development of the coronavirus.

We are confident that we have made the right decision in the interest of the health of our customers, technology partners, and employees.

Preparations had already largely been completed and we were all very much looking forward to this event, which has become a fixed date in many people's diaries. Postponed is not abandoned however and we are full of positive anticipation that we will be able to welcome you very warmly here in VS-Oberschach next year.

We will select the new date towards the end of this year and then inform you promptly via our Schwanog News media, our newsletters and website.

We wish that all of you will master this extraordinary situation and remain in good health. We look forward to seeing you again soon in person in the course of the year as part of our daily business.

Your Schwanog Technology Days organization team.

New apprentices take off at Schwanog:

TRAINING AS A CENTRAL MEANS OF SECURING THE FUTURE!

Since September 2019, three young people are again being trained at Schwanog to become specialists in their chosen professions.

We warmly welcome Lara Flaig, who has decided to become an industrial commercial clerk with additional qualifications in international business management. Since part of her training is also devoted to foreign languages, this combination offers her excellent prospects for a future at Schwanog with an international outlook.

Alexander Wolf and Malcom Trost are being trained at Schwanog to become first-class cutting machine operators. After successfully completing their training, both young men are to strengthen the production team in the grinding and wire-cutting area.

For Schwanog, training young people is not only a socio-political task, but it also helps secure the future availability of highly qualified specialists.

We wish all trainees an experience-rich apprenticeship and much success.



Change faster, finish faster, for significantly higher productivity:

THE STEP DRILL WITH INSERTABLE TOOLS AS A SERIES STAR!

Particularly in series production with large lot sizes, the focus is on production strategy and often on the optimization of the tool changeover process.

Using a solid carbide drill; once perished the entire tool must be replaced with a new tool and readjusted.

This is exactly where our step drill with insertable tools offers enormous time and cost advantages, and thus very quickly advances to become the series star in every production facility.

Benefits offered by the insertable drill:

- Tool changeover is significantly faster than with a solid carbide tool
- Separate adjustment of the drill insert after a tool changeover is eliminated
- Once perished, only the corresponding drill insert is changed, not the entire tool
- Drill insert cost is noticeably lower compared to a solid carbide drill
- Significantly lower coating costs, as only the insertable drill insert is coated

Benefit from the advantages offered by our insertable form drills which in most cases will reduce your unit costs by more than 40%.

Schwanog insertable form drills. The series stars with productivity guarantee!

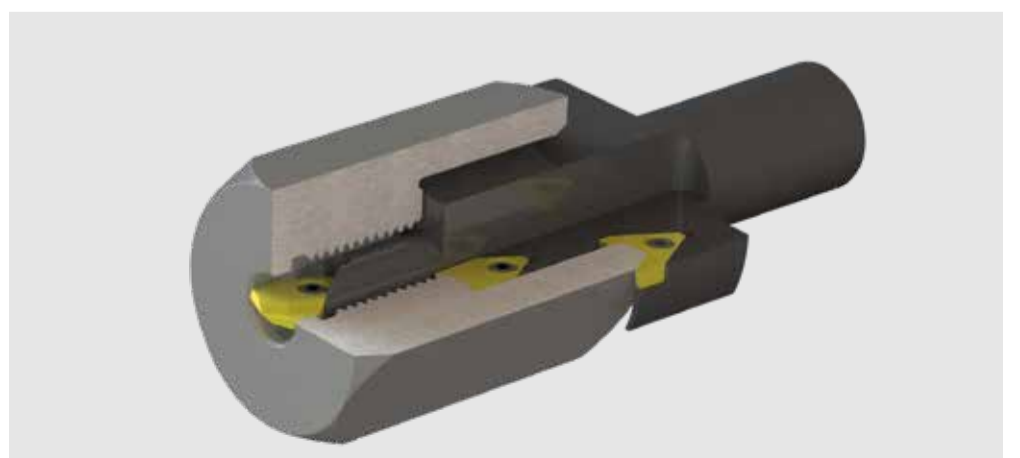
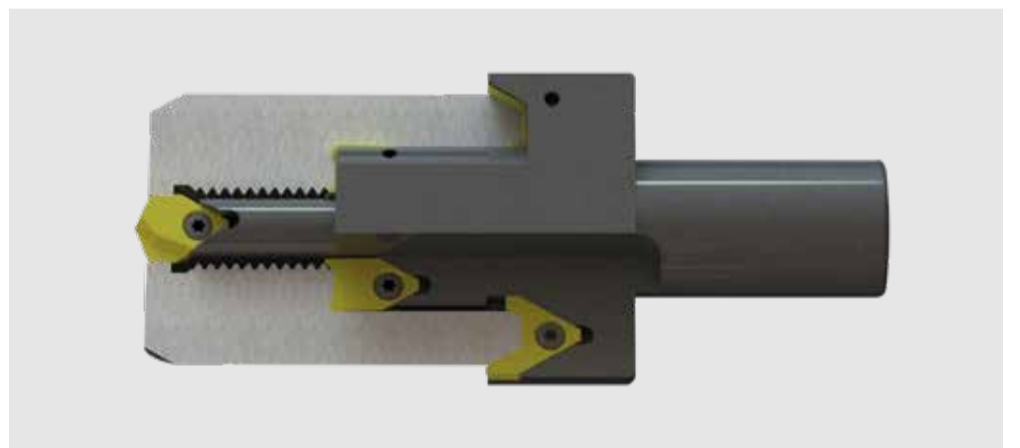

A great companion is leaving the ship:

FAREWELL FROM THE RETIRING DOMINIQUE ROSSETTO.



The Schwanog sales meeting provided a worthy setting for Dominique Rossetto's well-earned retirement on December 11, 2019 in Obereschach.

In his laudatory speech to all employees, managing director Clemens Güntert once again reflected on the years spent together, he highlighted the great successes and reviewed several amusing anecdotes.

As head of Schwanog France, Dominique Rossetto played a major role in the company's success in the French market and was able to inspire employees and customers alike with his integrity and expertise. On behalf of the entire Schwanog team, Mr. Güntert wholeheartedly wished him an experience-packed new phase in life. The culinary gift basket symbolizes the pleasurable moments in life; the gift voucher for motorcycle accessories should encourage his passion for motorcycles.

The meeting was of course also attended by the new head of Schwanog France, whom we would like to introduce briefly today.

Franck Manera,
new head of Schwanog France

Franck Manera is 52 years old, married, and a proud father of a daughter. After studying mechanics and production at the Université Savoie, Franck spent 4 years with a CNC machine tool dealer, where he was responsible for the installation of machines and machine systems, maintenance and training.

This was followed by 27 years of professional experience at a large turnery, 10 years of which as project manager and 17 years as key account manager, where Franck was able to combine his technical know-how with his sales talent. We are very pleased to have gained Franck Manera as a new employee, a person who brings with him all the prerequisites for the successful further development of Schwanog France.



Schwanog employees make private donations:

SUPPORT FOR THE CARL ORFF SCHOOL!



The private Christmas fundraising campaign by Schwanog employees becomes a tradition. The Carl Orff School in Villingen-Schwenningen was the recipient of this donation at Christmas 2019.

The Carl Orff School is a special educational school located in the Schwarzwald-Baar region. It was founded in 1969 as a special school for children and young people with learning difficulties. The aim is to educate the students in such a way that they can live as independently as possible later.

This includes learning everyday activities such as shopping as well as preparing for later working life. The impressive sum of €1,015 was collected. Again, this year, company managing director Clemens Güntert doubled the amount and rounded it up.

Thus, during a visit to the Carl Orff School, a cheque for €1,100 was proudly handed over.

Our photo shows teacher Mr. Hilser with some pupils together with Schwanog managing director Clemens Güntert, Julia Mauch and Andreas Kienzler as they hand over the cheque.



Schwanog · Siegfried Güntert GmbH
Niedereschacher Str. 36 · D-78052 VS-Obereschach
Tel. +49 (0) 77 21 / 94 89-0 · Fax +49 (0) 77 21 / 94 89-99
info@schwanog.com · www.schwanog.com

Schwanog LLC
1301 Bowes Road, Suite A · Elgin, IL 60123
Phone: 847-289-1055 · Fax: 847-289-1056
info.usa@schwanog.com · www.schwanog.com