

NEWS.

THE SCHWANOG NEWS FOR CUSTOMERS,
EMPLOYEES, AND FRIENDS OF THE COMPANY.

PAGE
02 Schwanog supports Steinco!
Quick availability of hospital bed rollers during
the Corona Pandemic...

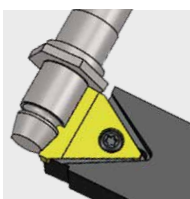

PAGE
03 Home office efficiency during the Corona crisis!
The Schwanog IT department makes it possible and
organizes the complete infrastructure...



Clear the stage for the Schwanog MSIK
innovation:

THE NEW MODULAR TOOL SYSTEM WITH COOLANT THRU FEATURE!

PAGE
03



EDITORIAL:

Dear business partner,

The corona pandemic hit our company with
unprecedented force.

All locations were hit at different times,
starting with China and ending in the USA.

We have done everything to protect our
employees against the virus at the various
locations and thereby have also significantly
expanded the amount of home office
activities. Please also read the report about
our IT Department on page 3, which, in a very
short time created optimum working
conditions for our employees.

Our project report on page 2 will guide you to
news about our customer Steinco, who is
working with hospital bed rollers, these being
a valuable commodity during the Corona
Pandemic. We were able to support Steinco
with the shortest delivery times for our PWP
insertable form tool system.

We would especially like to draw your
attention to our innovation, the MSIK modular
tool system. The big advantage of MSIK it
does away with coolant hoses and tubes due
to its coolant through feature.

Let us together exploit all the potential that
will help us to recover from the corona crisis
with success.

**We are ready – with our tooling systems,
with our motivated team and with our
willingness to do everything to promote
your success.**

Clemens Güntert
Managing director

SCHWANOG

Steinco gets involved and Schwanog provides full support:

QUICK AVAILABILITY OF HOSPITAL BED ROLLERS DURING THE CORONA PANDEMIC.

Steinco, based in Wermelskirchen, is one of the world's leading manufacturers of rollers and wheels, some of which are developed to meet specific customer requirements. Steinco has won numerous design awards, serving industrial sectors like medical technology and serving manufacturers of hospital and healthcare beds.

During the corona pandemic, the demand in hospitals and nursing homes for beds increased sharply worldwide, therefore also the production of rollers had to be massively increased in a very short time. Hospital bed rollers are, a small, but essential detail if patients in beds are to be provided with the care they need.

Right from the start, Steinco was convinced that it could make a great contribution by maximizing the speed of production and thereby provide immediate and tangible support to make additional hospital beds available.

Schwanog was immediately on hand as a partner

Steinco asked Schwanog for the shortest possible delivery time for the supply of part-specific form tools, for machining wheel axles on hospital bed rollers. For Schwanog's boss, Clemens Güntert, this was not only a professional challenge, but also a matter of deep personal concern in these days of the corona pandemic.

Not only was the fast delivery of the form tools important for the proposed solution, but also the highly efficient production of the axles themselves, in order to save further valuable time.

The solution is OD grooving with the PWP system

The Schwanog engineering team chose the PWP system because it offers a perfect grooving width to produce axles in combination with the most cost-effective solution.

OD grooving with the Schwanog PWP system is a typical example of the high production efficiency. Schwanog tooling systems always consist of a system holder and an insertable tool in which customer-specific contours are ground or wire-cut.

As a result, Schwanog form tools achieve a reduction in part costs of more than 40 % compared to single point turning. The distinguishing



Steinco's deputy head of the turning shop, Dietmar Höhler (left), together with Schwanog's Jörg Hönle

features of all Schwanog solutions are high surface finish quality and substantial time savings during tool changeovers.

The PWP system is available for cutting widths from 9 up to 33 mm and can be used on all lathes.

It's all a question of time – speed wins

The turnaround time was decisive for Steinco. Schwanog optimized its processes so that the inserts, which are manufactured precisely to drawing, can be produced in the shortest possible time.

Taking Steinco as an example, the entire process between order placement for the new part and the delivery of the Schwanog tools required only 6 days.

This fact also inspired Steinco's Dietmar Höhler:

"In our initial plans we assumed a delivery time of at least 10 days. Therefore, I would like to express my appreciation and thanks to the whole Schwanog team for producing a new part with such perfection in such a short time"

We at Schwanog strongly advise manufacturers, especially in the medical sector, to consult us about their machining requirements. We can offer a wide range of solutions that considerably reduce unit costs and increase quality.

These include thread whirling, or OD and ID grooving, insertable and solid carbide form drills and solid carbide milling cutters, just to name a few.

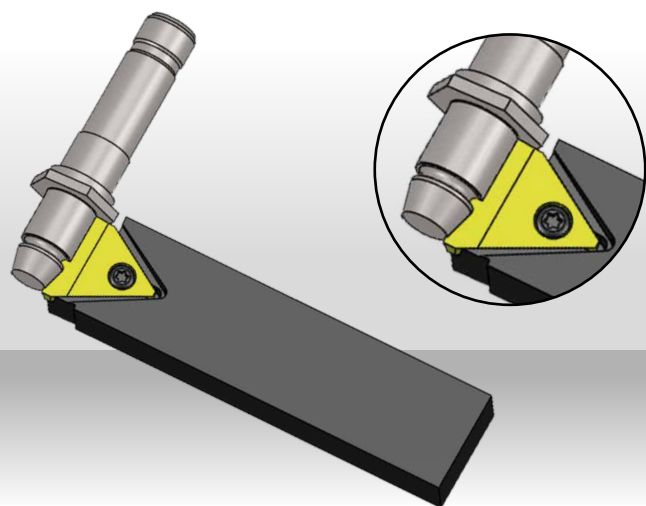

Schwanog PWP system for machining axles of hospital bed rollers

More power for Schwanog USA:

MATTHEW CRIDER STRENGTHENS THE TECHNICAL SALES TEAM!



Matthew Crider has strengthened the Schwanog inside sales team in technical sales starting in January 2020. Matthew successfully graduated in "Industrial Technology" from the MTEC in 2008. Further training followed in 2013 with his graduation from GRCC in "Mechanical Design" followed by certificates in: Scrum, Six Sigma Green Belt, BA and PMP.

In his professional career, Matthew worked as a machine setter and programmer of CNC machines and was previously active in injection molding technology.

In the last 6 years his tasks were in the area of "custom-made products" for various machine manufacturers and most recently in project management for custom developed CNC and grinding machines.

With this wide range of experience, Matthew is an excellent addition to the Schwanog team, and we are happy that he will strengthen our team with his expertise.

His hobbies are as varied as his professional experience: these include sports such as running in marathons, golf, his family and trips to visit relatives in Florida, Tennessee and Michigan. He is motivated to participate actively in charity events to help other people who are in urgent need.

Clear the stage for the latest innovation from our think tank:

THE SCHWANOG MSIK MODULAR TOOL SYSTEM WITH COOLANT THRU FEATURE!

Manufacturers of precision parts in the machining industry can now look forward to a significant improvement in their processes with the modular tool system MSIK. Schwanog has developed an innovative solution through which the coolant is supplied internally and directly to the cutting edge via the base body and cartridge.

The big advantage

The internal coolant supply needs neither coolant hoses or tubes nor adjustments!

Starting point for innovation

Modular tooling systems are increasingly being used in the metal cutting industry because they offer significant advantages over conventional changing and clamping systems and thus offer the user added value. The basic principle and central advantage are that

the tool holders can be preset parallel to the machining process and are thus available on the machine and ready for use. Modular tooling systems are characterized by high flexibility and a significant reduction in tool inventory which leads to a reduction in tool costs for all machining operations. A tool change via the tool changer is faster, more reliable and easier than changing inserts manually in the machine.

Structure of the MSIK tooling system

Different standardized cartridges for grooving can be used on the basic body, which is designed with a machine interface. The interface to the cartridges is screwed to the side of the base body ensuring a stable and secure connection. Cartridges are available for the WEP and PWP tooling systems.

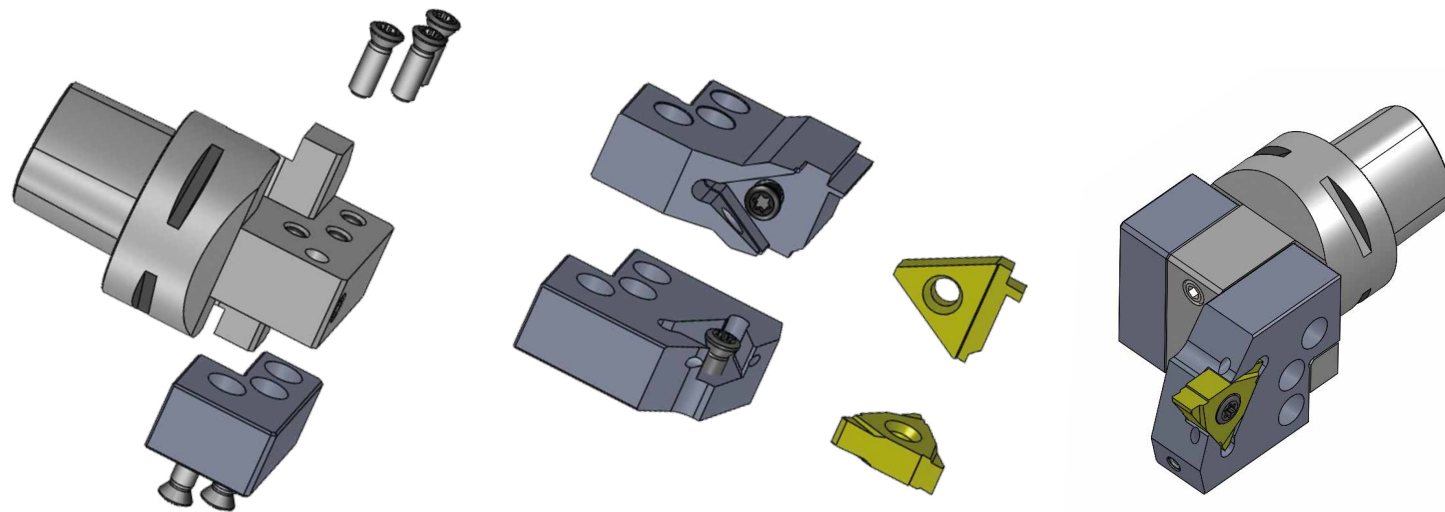

System highlights

Interface base body:

- Polygon shaft ISO 26623 (Capto) C3, C4, C5, C6
- Design with and without serration (without serration shorter overall length)
- HSK-T63 (Turning Standard) ISO12164 Design with and without serration (without serration shorter overall length)
- TS system ISO 26622 TS40,50,63

Basic body is available in right, left and neutral versions:

- Neutral version with 2 cartridge seats (only 1 base body required for right and left tools)
- Right and left cartridges (Tool holder) for WEP and PWP system
- Internal coolant supply via base body and cartridge directly to the cutting edge

Special designs:

- Customer-specific designs on request

Home office efficiency in the Corona crisis:

THE SCHWANOG IT DEPARTMENT MAKES IT POSSIBLE!

The Corona crisis has also struck our companies forcing us to take steps to protect our employees from infection while maintaining operations.

Our IT department made a major contribution to this. Within a few days, the home office share of administration tasks was increased internationally from a very low percentage to 80%. It is remarkable that the complete design department moved to a home office within 2 days. Many processes have been digitized at short notice for this purpose. Since then every day processes have been further adapted to ensure the optimum home office coordination with staff that remain in the company. In addition, further technical optimization is planned for the coming weeks aimed at establishing long-term, home-based, working and to introduce new communication technologies within the company.

All this was made possible by the foresight of the IT department and consistent investment in future-oriented technologies. The introduction of CAD virtualization in 2019 came at just the right time. For the problem-free relocation of administrative tasks, different technologies were used depending on each individual requirement. But also, the flexibility of the ERP system provided its contribution to the success of Schwanog's pandemic strategy. With Sage ERP b7 and the development environment BOA, all processes can be quickly and reliably adapted to the situation which is changing daily.



Carsten Schwabe



Daniel Brandi

Zoran Timotic strengthens the IT team

Indeed, we have not only invested in IT technologies, but also in manpower. We are therefore very happy to have Mr. Zoran Timotic in our IT department, a proven specialist with over 20 years of experience as an IT administrator.

After his apprenticeship in information technology, he participated in numerous training courses and eventually graduated as an IT specialist (HWK) at the trade academy in Villingen. Mr. Timotic added numerous Microsoft certifications to round off his profile. As a trainer in the IT sector, he has prepared trainees for their professional life.

At Schwanog he has already been able to contribute his know-how to numerous projects – from the introduction of CAD virtualization to the implementation of home offices during the current Corona crisis. To improve communication between colleagues in their home offices and customers and suppliers, Zoran Timotic integrated Microsoft Teams in the infrastructure in the shortest possible time. The entire IT team



Zoran Timotic

does first-class work here and supports staff within the company and those in their home offices with a high-level of commitment.

Mr. Timotic is 37 years old, married, and lives in VS-Schwenningen. How does he spend his spare time? He is passionate about soccer, basketball, and technology. And when time allows, he likes to travel to his home country, Serbia.

Our products fit any holder:

SCHWANOG SOLUTIONS FOR ALL STANDARD AND SPECIAL HOLDERS!

As diverse as the market for machine tools is, so broadly diversified is also the associated range of tool holders and Schwanog offers a solution for every holder.

Standard tool holders as used on single and multi-spindle lathes, such as those with a rectangular and round shank, the dovetail (AWN) and block type have been part of our portfolio for decades. But also, all common taper and special holders such as Capto, HSK, SK or UTS have been successively included in recent years. Today, perfectly fitting solutions are offered for all sizes as well as all Schwanog insertable form tool systems.

Furthermore, our team has also developed tool holders that can be adjusted vertically and laterally according to customer-specific specifications, for example, tool holders with internal cooling. These are optionally available with adjustable coolant jets.

The advantages:

- Optimum integration of the Schwanog system with all common tool holding systems.
- Significant cost reduction through reduced set-up times.
- Highest efficiency when using the Schwanog system with part cost reductions of up to 40%.

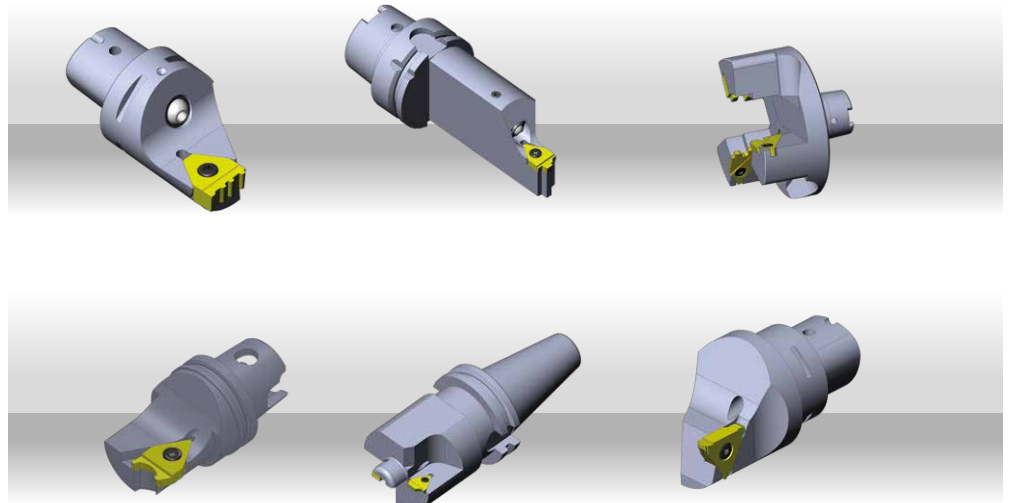

The modular basic structure of the Schwanog changing system opens almost limitless possibilities. As a result, today, all Schwanog product lines can be optimally integrated on any standard mounting system.

We are thus creating perfect conditions to enable every manufacturer of precision parts to benefit from our system advantages.

A multifaceted life, both professionally and privately:

ALEXANDER LEHMANN CELEBRATES HIS 10TH SCHWANOG-ANNIVERSARY!

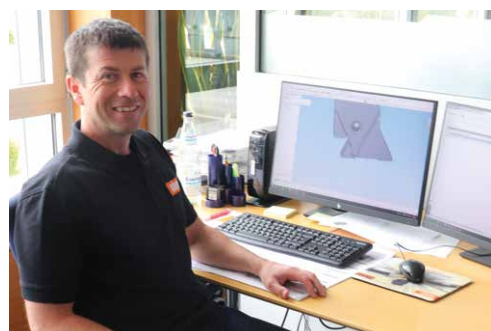

Alexander Lehmann at work at Schwanog

In February, Alexander Lehmann celebrated his 10th anniversary at Schwanog. He was congratulated by managing director Clemens Güntert and all his colleagues.

Alexander Lehmann is a design engineer at Schwanog and is responsible for all application areas.

Alexander Lehmann has actually been with Schwanog for much longer, but his deeply rooted faith led him to a 1 ½ year voluntary service period in Costa Rica.

The idea for this had been maturing in him for a long time and so he used the opportunity to enrich his life by a missionary period with the Movida organization. His motivation was to bring the Christian faith closer to people in a distant country like Costa Rica and to find time for himself.

Since February 2018 Alexander Lehmann has been back at his workplace at Schwanog in Oberschach. The many and varied impressions have remained with him. Whether it was the learning of the Spanish language, living in an environment of great poverty, or the formative cordiality in dealing with children and young people. Movida also used its strengths for the logistic organization of major events, which gave him additional new experiences.

Alexander Lehmann greatly appreciates the fact that Schwanog kept his job free for him during his voluntary service, which enabled him to start working in his job again immediately upon his return.



Alexander Lehmann in Costa Rica (photo: Schwarzwälder Bote newspaper)

Successful training:

CERTIFICATE PRESENTATION TO LORENZ HERBST, METAL-CUTTING MECHANIC!



Young, successful and full of enthusiasm – this is how our latest addition to the Grinding Technology team gets things done. Lorenz Herbst has, at the young age of just 20 years, successfully passed his examination with flying colors as a metal-cutting mechanic!

Since February 2020, Lorenz Herbst has been strengthening the grinding technology team at the Oberschach location. His new colleagues appreciate his friendly manner and his willingness to continuously develop his profession.

In his spare time Lorenz likes to be fast on the road. Racing and motorcycling are his favorite

hobbies through which he can enjoy the beautiful local Black Forest landscape.

Our photo shows managing director Clemens Güntert congratulating and presenting the certificate – with great pleasure, and in these times with due distance.

The entire Schwanog team is delighted with his first-class test result and wishes Lorenz Herbst all the best for the future at Schwanog.



Schwanog · Siegfried Güntert GmbH
Niedereschacher Str. 36 · D-78052 VS-Oberschach
Tel. +49 (0) 77 21 / 94 89-0 · Fax +49 (0) 77 21 / 94 89-99
info@schwanog.com · www.schwanog.com

Schwanog LLC
1301 Bowes Road, Suite A · Elgin, IL 60123
Phone: 847-289-1055 · Fax: 847-289-1056
info.usa@schwanog.com · www.schwanog.com