

NEWS.

THE SCHWANOG NEWS FOR CUSTOMERS,
EMPLOYEES, AND FRIENDS OF THE COMPANY.

PAGE
03 **Tools for all common broaching attachments:**
Schwanog offers suitable broaching tools for almost all broaching attachments, which are made from carbide or high-speed steel depending on the application...



PAGE
03 **6. Schwanog Technology Days 2022:**
All technology partners have agreed, and we are already looking forward to an interesting and exciting event ...

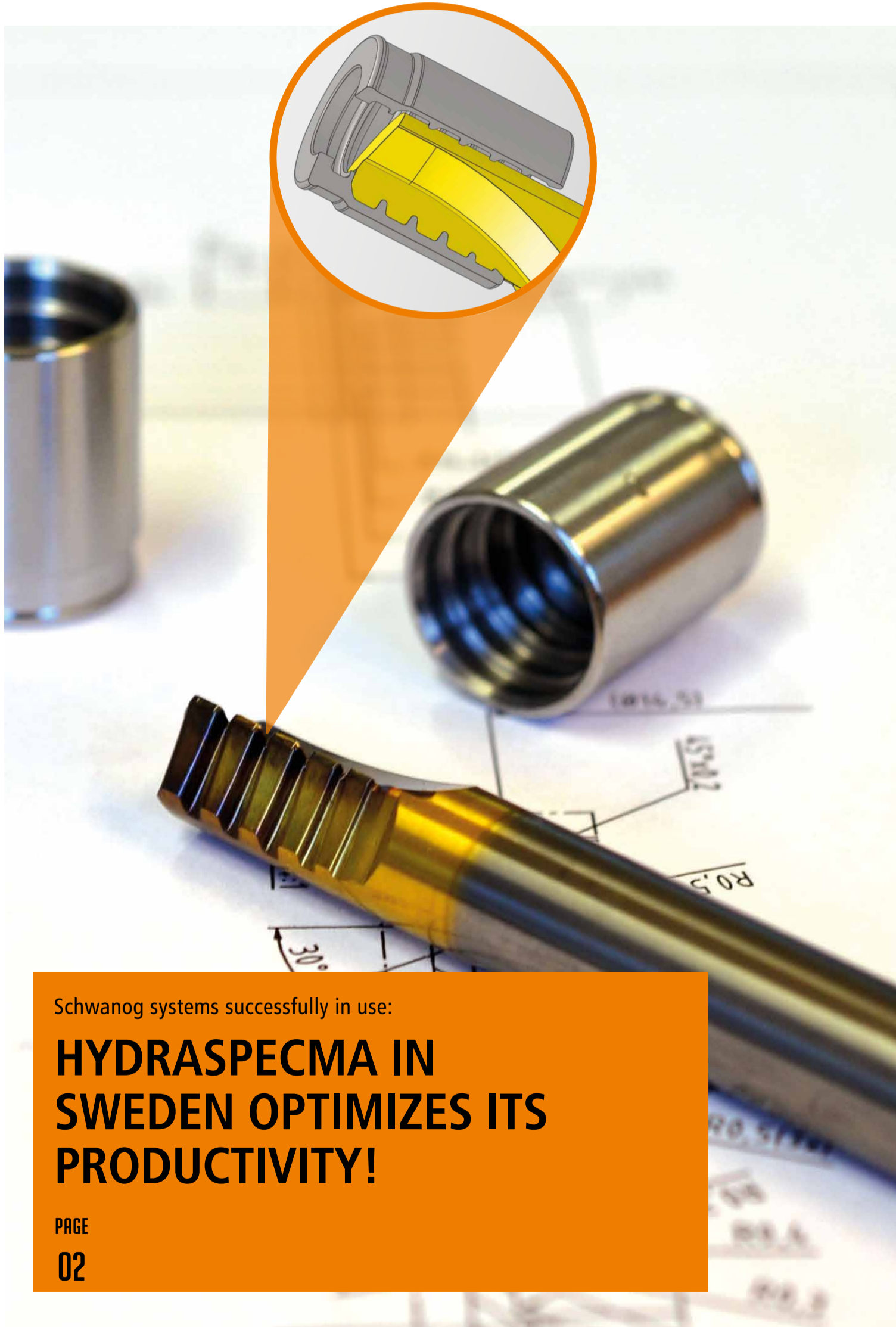

Schwanog systems successfully in use:

HYDRASPECMA IN SWEDEN OPTIMIZES ITS PRODUCTIVITY!

PAGE
02



EDITORIAL:

Dear business partner,

We started our new fiscal year with a positive development and are taking this momentum along with us into our work on the market. Thus, in the first issue of our News in 2022, we are once again presenting you with exciting reports and news from the world of Schwanog.

Our title cover with the story on page 2 presents our successful collaboration with the Hydra-Specma company in Sweden. It is the best example of how costs and handling can be significantly optimized with clear objectives, good advice, and innovative Schwanog tooling solutions.

The focus of this News is also the 6th Schwanog Technology Days, which we will be holding with much motivation on June 22nd and June 23rd, 2022. Preparations are in full swing, and I would especially like to thank our events team and our technology partners who have already confirmed their commitment. In this connection, I am especially pleased to welcome you on behalf of our team.

I would also like to call your attention to our technical news on page 3 of this news. Here everything revolves around the broaching of grooves and serrations with Schwanog tools that we have developed for all common broaching attachments.

Reports on Stefan Kaiser's company anniversary, the awards from our improvement suggestion system, and a look back at the first trade shows this year will round out this issue.

Use our solutions to optimize your unit costs.

We are ready for you – worldwide!

Clemens Güntert
Managing director

External and internal grooving with Schwanog tooling systems:

HYDRASPECMA IN SWEDEN OPTIMIZES ITS PRODUCTIVITY!

With a clear specialization strategy that focusses on the development and manufacture of hydraulic connectors, the HydraSpecma company in Sweden is on a path to dynamic growth. HydraSpecma employs around 1,100 people at its Våxtorp location and is part of the Denmark-based, listed group Schouw & Co.

The philosophy of the company is shaped by its drive for the ongoing optimization of productivity and processes, from development to prototyping, all the way up to production. Hydraulic connections for the assembly of hydraulic hoses that are individually adapted to various systems and components is the proven core competence of HydraSpecma. With this specialization, the company is now one of the market leaders in Scandinavia and is also increasingly in demand in important global export markets.

Swiss turning as an important machining method

Fredrik Schoenbeck and Jacob Schoen are responsible for the production processes at the company, and they are currently expanding the manufacturing plant with additional swiss-type lathes and automation solutions.

Frederik Schoenbeck explains:

"Swiss turning is a central processing method within our production. We are currently using 17 STAR machines with a bar magazine and 17 multifunctional lathes from manufacturers such as MAZAK, OKUMA, MIYANO, and INDEX, which are fully integrated into fully automatic turning cells."

In 2021 alone, the company invested in several new automatic lathes and four new robot cells. More than 3,000 different products are manufactured every year, with around 200 items being continuously manufactured in larger quantities.

Increasing productivity is an ongoing task

The company's objective is clearly defined. With increasing quantities, production must be faster, and active measures need to be implemented to increase productivity over the long term.

In the field of tool optimization, the company approached Schwanog. As a specialist for application-specific tooling solutions, Schwanog enjoys an excellent reputation in Sweden as a productivity optimizer. Jonas Lund, who has been respon-

sible for Schwanog's sales in Sweden for three years, met with Fredrik Schoenbeck and Jacob Schoen to discuss specific projects and productivity goals.

HydraSpecma needed optimization in terms of productivity in three specific applications. The possible solutions were quickly recognized by Jonas Lund, who then coordinated the detailed technical implementation with the Schwanog design team in Germany. Within just a few days, solutions were presented that led to impressive results for HydraSpecma.

WEP system for external grooving

The Schwanog WEP system was used for external plunge cutting of grooves on a turned part. A special feature of the Schwanog WEP system is the design with three cutting edges. If the first cutting edge is worn, the tool can simply be indexed to the next edge and fixed by loosening a single retaining screw.

Due to the quick changeability of the tools and high repeatability, work can usually continue immediately during tool changeovers without readjustment of the tool. The WEP systems cutting widths ranges from 3.5 to 16 mm.

WSI system for internal grooving

With the WSI system, the internal contours of a specific turned part can now be manufactured much more efficiently by grooving instead of single-point turning. The Schwanog WSI system enables internal grooving, internal single-point turning, or both production steps in one operation. The tool holders include coolant-through and are available in metric and inch sizes. Diameters > 2 mm can usually be realized.

The length of the internal grooving tools can be infinitely adjusted via an adjusting screw in the Z-axis and thus can offer optimal stability and functionality during setup and tool changeovers. Repeatability of the WSI system is < 0.02 mm.

Solid carbide grooving tool

With Schwanog's solid carbide grooving tool, HydraSpecma was able to achieve the inner contour of a turned part much faster than before. Due to the cutting width, solid carbide was chosen for stability and space reasons.

In addition to increasing productivity, quality also plays a decisive role in the further growth of the company. Since the products are used in environments where high hydraulic pressures prevail, HydraSpecma customers also demand the highest quality in products and production processes without any compromises. Schwanog also fulfills this requirement convincingly in all three applications.

The advantages:

- Enormous time savings
- Easy handling for the operator
- Only one tool is now used for each turned part, whereas previously several tools were required
- Only one measurement needs to be carried out

Jacob Schoen puts it this way:

"The Schwanog tooling systems have significantly improved our ability to reduce set-up times, improve quality, extend tool life, and at the same time make our manufacturing processes more efficient".

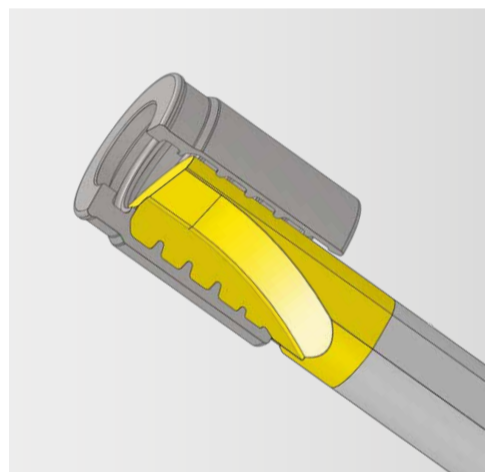

Schwanog solid carbide grooving tool for machining inner contours

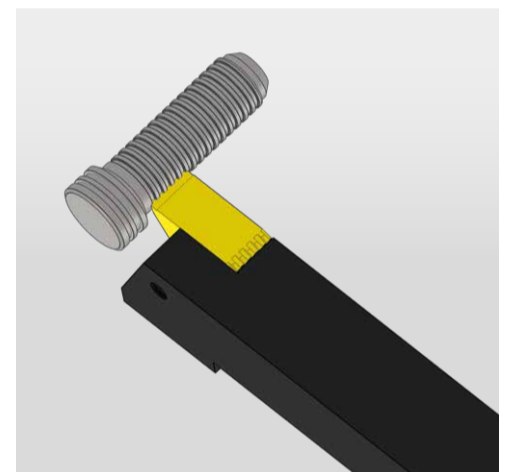

Schwanog WEP system for external plunge cutting of grooves

Many thanks for years of cooperation:

STEFAN KAISER CELEBRATES HIS 10TH ANNIVERSARY.

Stefan Kaiser is now one of the deserving employees who have been working for Schwanog for more than 10 years. For us as a company, this is the best confirmation of our corporate culture and the central pillar of our success.

After successfully completing his apprenticeship as a tool-maker, he continued working in this field. He then gained additional experience in a long-term position where he was responsible for die-sinking. With this profound basis, Stefan Kaiser moved on to Schwanog 10 years ago and is

now an important member of Schwanog's wire-cut department.

Stefan Kaiser is married, has two children, and is passionate about his numerous hobbies. They include skiing, hiking, working with the local soccer club, tinkering, and working on vintage mopeds as well as exploring the local countryside.

We wish Stefan Kaiser all the best for his future at Schwanog.



from left to right: Production Manager Franz Hummel, Stefan Kaiser, Department Manager Carsten Schwabe

Save the Date:

WELCOME TO THE 6TH SCHWANOG TECHNOLOGY DAYS 2022!

With great motivation and joy, our event team is working on the preparations for the 6th Schwanog Technology Days on June 22nd and June 23rd, 2022, and we cordially invite you to attend. After the cancellation in 2020 due to the pandemic, we all hope to be able to hold the event in the usual way this year.

We are very pleased that in the meantime all our technology partners have already agreed to attend, and we can once again offer you an exciting and varied program. Our partners Eppinger, Goltenbodt, H&K, Welter Werkzeugtechnik, WTO, Zoller, Hainbuch, Schlenker, and Manuhrin will contribute to a successful event with topics that focus on part cost reduction, quality, and process efficiency.

We view personal dialogue as an important part of our event, especially since the past two turbulent years have shown how important partnerships are for medium-sized companies like ours.

We would also like to take advantage of this event by inviting you to celebrate our 75th anniversary together. Therefore, it would be great to register today so that our team can plan for the number of attendees at an early stage.

With this in mind, we look forward to your registrations and wish you all the best, health, and a pleasant journey until then.



Please register via our website:



We welcome you to confirm your participation by email or telephone:

- 6th Schwanog Technology Days
- Thursday, June 22nd from 9:00 a.m. to 4:30 p.m.
- Friday, June 23rd from 8:30 a.m. to 4:30 p.m.

email: info@schwanog.com
Telephone: +49 7721 9489-0

TECHNOLOGY PARTNER



Schwanog tools for all common broaching attachments:

OPTIMIZED MACHINING OF GROOVES AND SERRATIONS!

Grooves and serrations can be machined on CNC machines either by using a spindle or turret or by using a special broaching attachment.

The machining strategy with broaching attachments offers a whole range of advantages for the user. With broaching attachments, the stress on the cost-intensive machining centers is significantly reduced. The machining process with broaching attachments also reduces unit costs due to faster machining times.

Broaching attachments for use on CNC machines are offered by a wide variety of manufacturers, such as Benz, Heimotec, EWS, Schwarzer, WTO, and ESA.

Schwanog offers suitable broaching tools for practically all broaching attachments, which are made either from solid carbide or high-speed steel depending on the application.

Schwanog broaching tools for serrations, grooves, and special forms are therefore a highly efficient addition to the conventional machining of turned parts. This way, complex forms, grooves, and serrations can be produced on a CNC lathe in just one operation. The otherwise conventional post-processing step on another machine is eliminated. Also eliminated is the necessary logistic of the parts along with the planning and control of this work step.

The advantages of all three solutions:

- Significant time savings
- Double-digit unit cost reductions
- Life of machine is prolonged
- Solutions available for all broaching attachments
- Broaching tools available in solid carbide and high-speed steel



Process optimization by our employees:

2ND YEAR OF SCHWANOG IMPROVEMENT SUGGESTION SYSTEM!

The Corona Pandemic has certainly ensured that in many companies that the focus of employees has been placed on central challenges.

We are more pleased that, despite these accompanying circumstances, numerous suggestions for improvement have been submitted. Management and the improvement suggestion committee would like to thank all employees who submitted suggestions. We look forward to further innovative ideas.

From the extensive number of suggestions, we have chosen the following top 3 for 2021:

TOP 1: AREA: SHIPPING DEPARTMENT

Suggestion: Adjustable fixture for series laser marking of drill holder blank
Source of the suggestion: Ms. Urte Thieringer-Lauble

A new fixture makes the process of laser marking drill holder blanks more efficient. The fixture makes it possible to position several drill holder blanks at the same time to laser mark them collectively. Thus, saving enormous time and achieving higher accuracy.

Status: The improvement proposal is in the implementation phase.

TOP 2 – AREA: WIRE-CUT DEPARTMENT

Idea: New resin bottle cap
Source of the idea: Mr. Stefan Kaiser

New screw connections are used to ensure that the inlet and outlet of dielectric bottles cannot be confused. This measure applies to process control and serves as a preventive measure to prevent the medium from leaking.

Status: The suggested improvement has already been implemented.



V.l.n.r.: Jens Serowy, Stefan Kaiser, Urte Thieringer-Lauble und Geschäftsführer Clemens Güntert

TOP 3: AREA: GRINDING DEPARTMENT

Idea: Material information provided by the customer on the final drawing (twist drill)
Source of the idea: Mr. Jens Serowy

To be able to check the function of a tool, test drilling is carried out, if necessary for new parts or modified parts. To ensure that this process can be carried out efficiently, the customer's material data has recently been added as standard information on the drawings. Thus, the production employee can immediately select the right material for the test drilling, and thus a long search for the material data is no longer necessary.

Status: The suggested improvement has already been implemented.

Congratulations to our apprentices:

SUCCESSFUL COMPLETION OF APPRENTICESHIPS IN THE INDUSTRIAL AND COMMERCIAL AREA.

Three of our apprentices have successfully completed their apprenticeship with both pride and joy. We would like to briefly introduce these three young employees to you:



V.l.n.r.: Dennis Deiter, Geschäftsführer Clemens Güntert, Lara Flaig, Ausbilderin Petra Grade, Ausbilder Partick Faller, Nils Königsberger

LARA FLAIG

Lara Flaig is 20 years old. Having successfully passed the exam as an industrial clerk with an additional qualification in international business management, she will strengthen our team as a clerk in sales. When asked about her hobbies, Lara said that she likes to participate in sports, dancing, and likes to get together with her friends.

DENNIS DEITER

Dennis Deiter is also 20 years old. Following his 3½-year apprenticeship as a metal-cutting mechanic, he will work in the grinding department manufacturing form tools. During his free time, Dennis enjoys sports, especially playing soccer.

NILS KÖNIGSBERGER

Nils Koenigsberg was also able to successfully complete his 3½ year apprenticeship as a metal-cutting mechanic. He will strengthen our milling department in the base holder production. During his free time, everything revolves around volleyball.

NEW APPRENTICE BEN LAESSIG

The introduction of our new apprentice Ben Laessig, who started his apprenticeship as a metal-cutting mechanic, also fits in perfectly with this topic. Ben is 17 years old and enjoys diving, cycling, and tennis during his spare time.



It's finally trade show time again:

SUCCESSFUL INTERNATIONAL TRADE SHOW APPEARANCES!

Trade shows are finally being held again. Our team took advantage of the opportunity by participating at FITMA in Mexico, Fornitore Offresi in Italy, and SIMODEC in France.

Business attendees could again feel some relief talking with their preferred manufacturers once again and discovering new potential for cooperation.

Our team has consistently given positive feedback, and we are already looking forward to our next trade shows, which we will announce shortly via various communication channels.



SIMODEC in Frankreich



FITMA in Mexiko



Schwanog · Siegfried Güntert GmbH
 Niedereschacher Str. 36 · D-78052 Villingen-Schwenningen
 Tel. +49 (0) 77 21 / 94 89-0 · Fax +49 (0) 77 21 / 94 89-99
 info@schwanog.com · www.schwanog.com